

Model **KX21**
for KART
PARTS CATALOG

Spec. No. EX210K80020



FUJI HEAVY INDUSTRIES LTD.



Find us on
Facebook

ISSUE EMD-EP6687

ISSUE DATE 2009. 3

FIG. 100

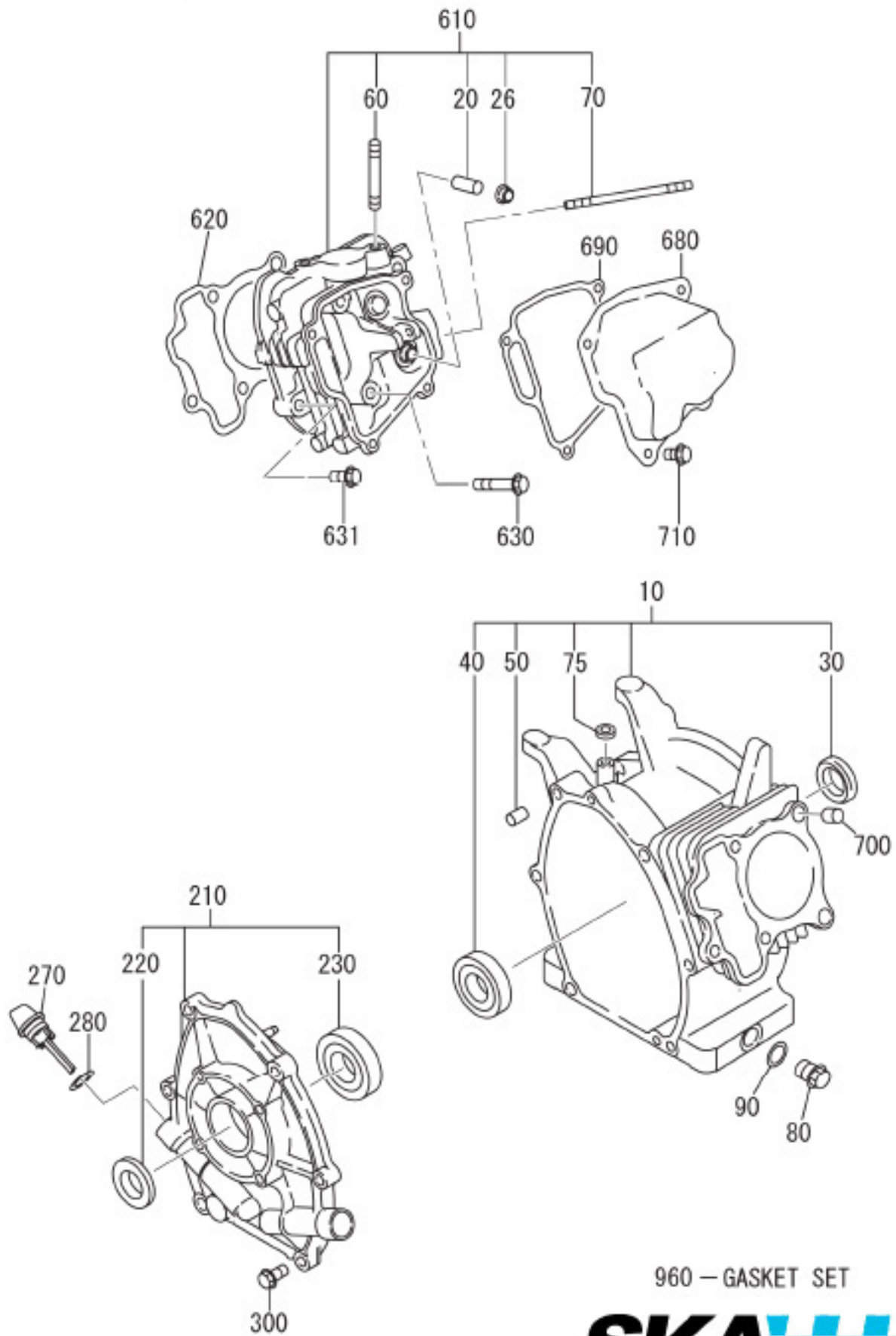

960 - GASKET SET

SKA 
 Subaru tuning association of **NSW INC.**

FIG. 200

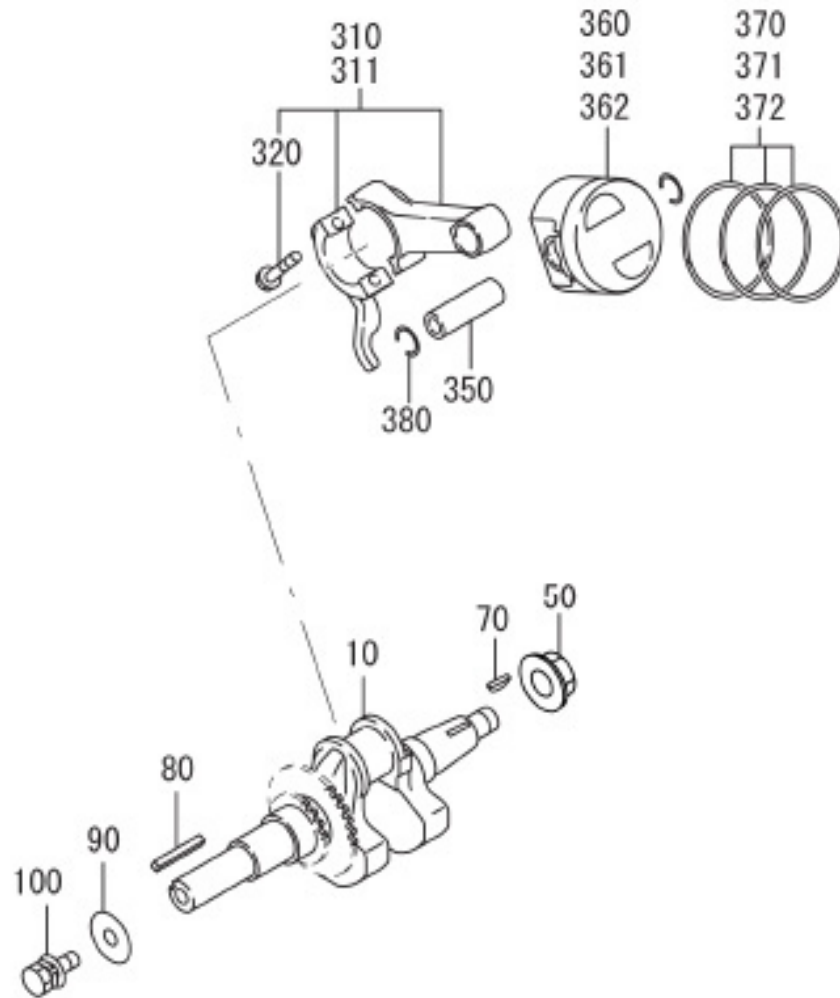
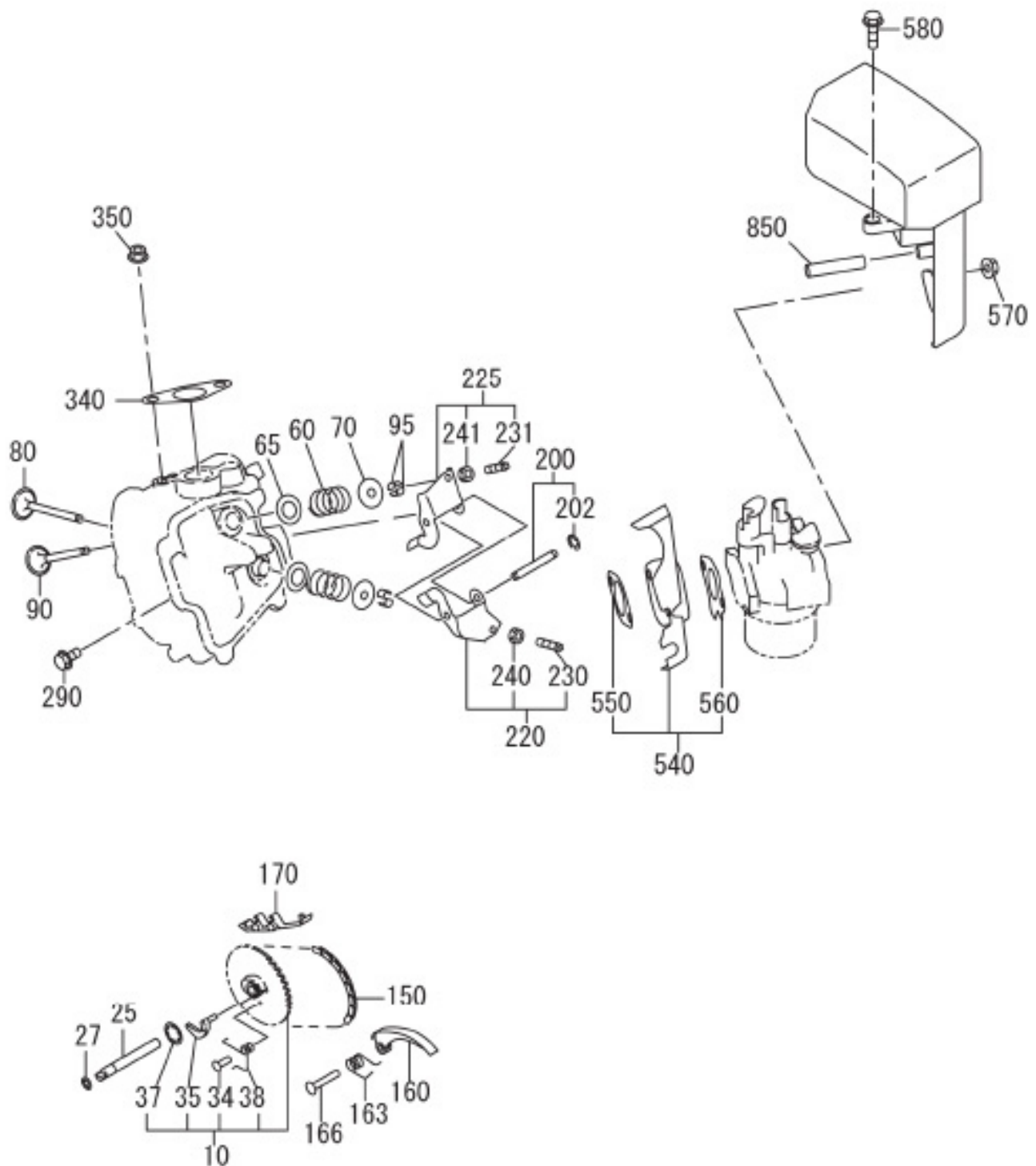

FIG. 300



3 INTAKE EXHAUST

REF.	PART NUMBER	PART NAME	QTY	R E M A R K S	CODE NO.	INTERCHANGE P/NO.	UNIT P	FIG.
10	278-31602-01	CAM SHAFT CP	1	85DX2. 9B N=40	-			300
25	277-35101-03	PIN(CAM SHAFT)	1	9DX78. 5L	-			300
27	024-00600-10	O RING	1	5. 8DX9. 6D	-			300
34	277-38601-03	PIN(SPRING)	1	4DX8DX9L	-			300
35	277-36401-03	RELEASE LEVER	1		-			300
37	278-38801-03	SPACER CAM	1		-			300
38	277-38702-03	RETURN SPRING	1	5. 1DX0. 6DX4. 4L N=7	-			300
60	279-33601-03	VALVE SPRING	2	19. 2DX2. 3DX27. 4L	-			300
65	278-38802-03	SPACER SPRING	2		-			300
70	269-33701-03	SPRING RETAINER	2		-			300
80	279-33401-H3	INTAKE VALVE	1	28. 5DX5. 5DX67. 8L	-			300
90	279-33501-H3	EXHAUST VALVE	1	26. 5DX5. 5DX67. 8L	-			300
95	132-10KA0-31	COLLET-VALVE	4		-			300
150	278-35601-11	TIMING CHAIN CP	1	92 LINK	-			300
160	277-36911-03	TENTIONER	1		-			300
163	277-37101-03	SPRING(TENTIONER)	1	10DX1. 8DX14L N=4. 5	-			300
166	277-36902-03	PIN(TENTIONER)	1	6DX13DX34L	-			300
170	277-36913-13	CHAIN GUIDE	1		-			300
200	277-35004-01	PIN(ROCKER) CP	1		7853-			300
	277-35003-03	PIN(ROCKER)	1		7731-7852			300
	277-35002-01	PIN(ROCKER) CP	1	6DX46L	-7730			300
202	003-13050-00	CLIP	1	5DX11DX0. 6T	-			300
220	277-36201-00	ROCKER ARM(IN) AY	1		-			300
225	277-36202-00	ROCKER ARM(EX) AY	1		-			300
230	014-90500-20	ADJUST SCREW	1	M5X0. 5X23L	-			300
231	014-90500-20	ADJUST SCREW	1	M5X0. 5X23L	-			300
240	017-00500-30	NUT	1	M5X0. 5X4. 1H	-			300
241	017-00500-30	NUT	1	M5X0. 5X4. 1H	-			300
290	011-00600-20	FLANGE BUL I	1	M6X1. 0X14DX12L	-			300
340	277-35201-13	GASKET(MUFFLER)	1	T=0. 2 26D 9DX58P	-			300
350	980-20082-80	FLANGE NUT	2	M8X1. 25X17DX7. 5H	-			300
540	279-32905-H0	INSULATOR AY	1		-			300
550	279-35903-J3	GASKET2 (INSULATOR)	1	T=0. 5	-			300
560	279-35902-J3	GASKET1 (INSULATOR)	1	T=0. 5	-			300
570	002-38060-00	FLANGE NUT	2	M6X1. 0X13DX6H	-			300
580	011-00600-50	FLANGE BOLT	1	M6X1. 0X13DX20L	-			300
850	279-32760-08	RUBBER PIPE	1	8DX11DX115L	-	085-10800-00		300

FIG. 315

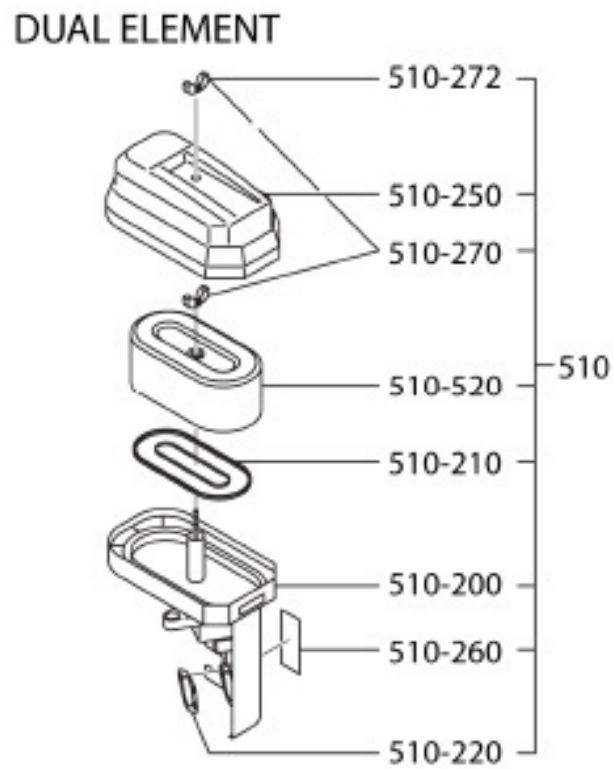

FIG. 400

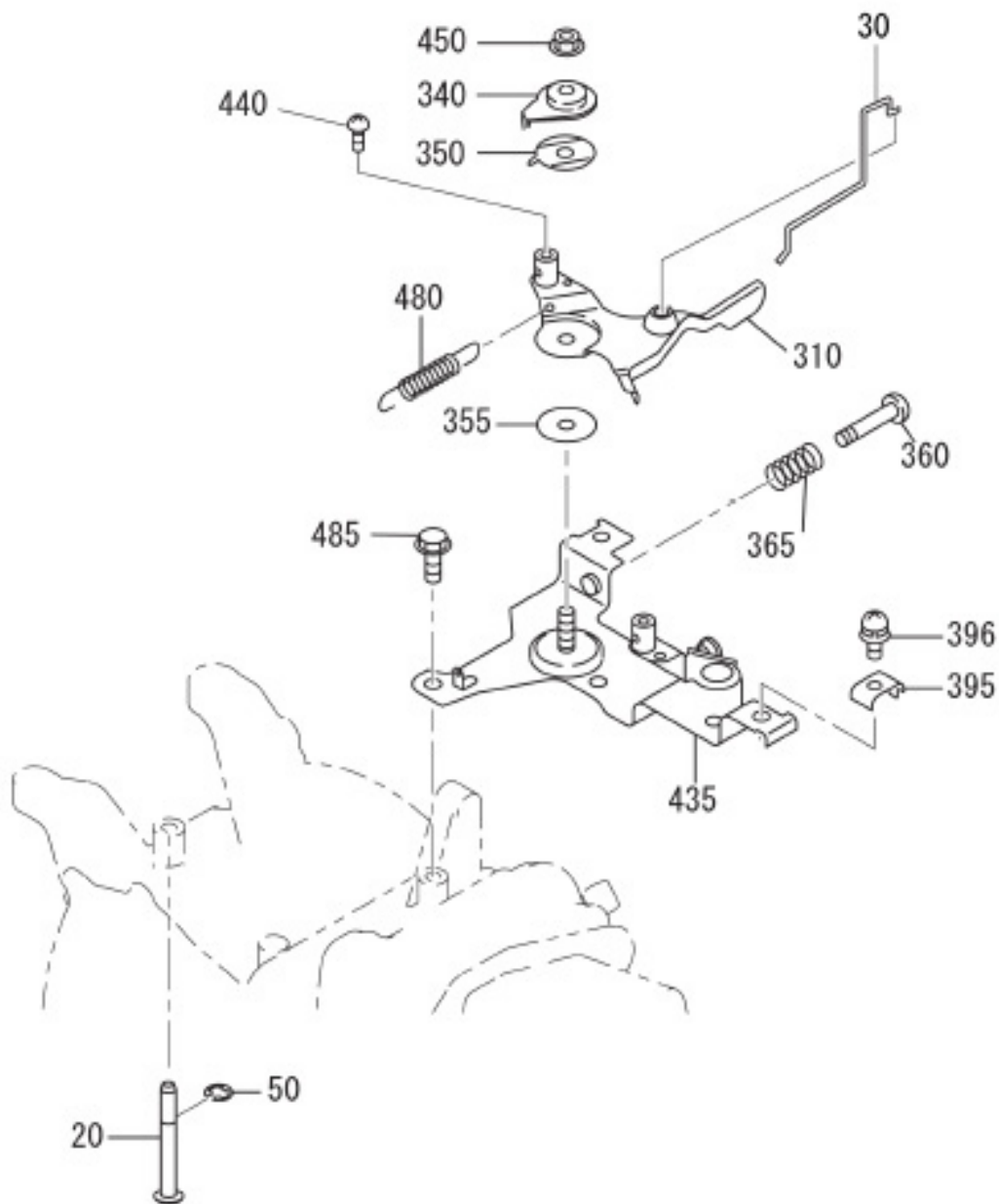

FIG. 500

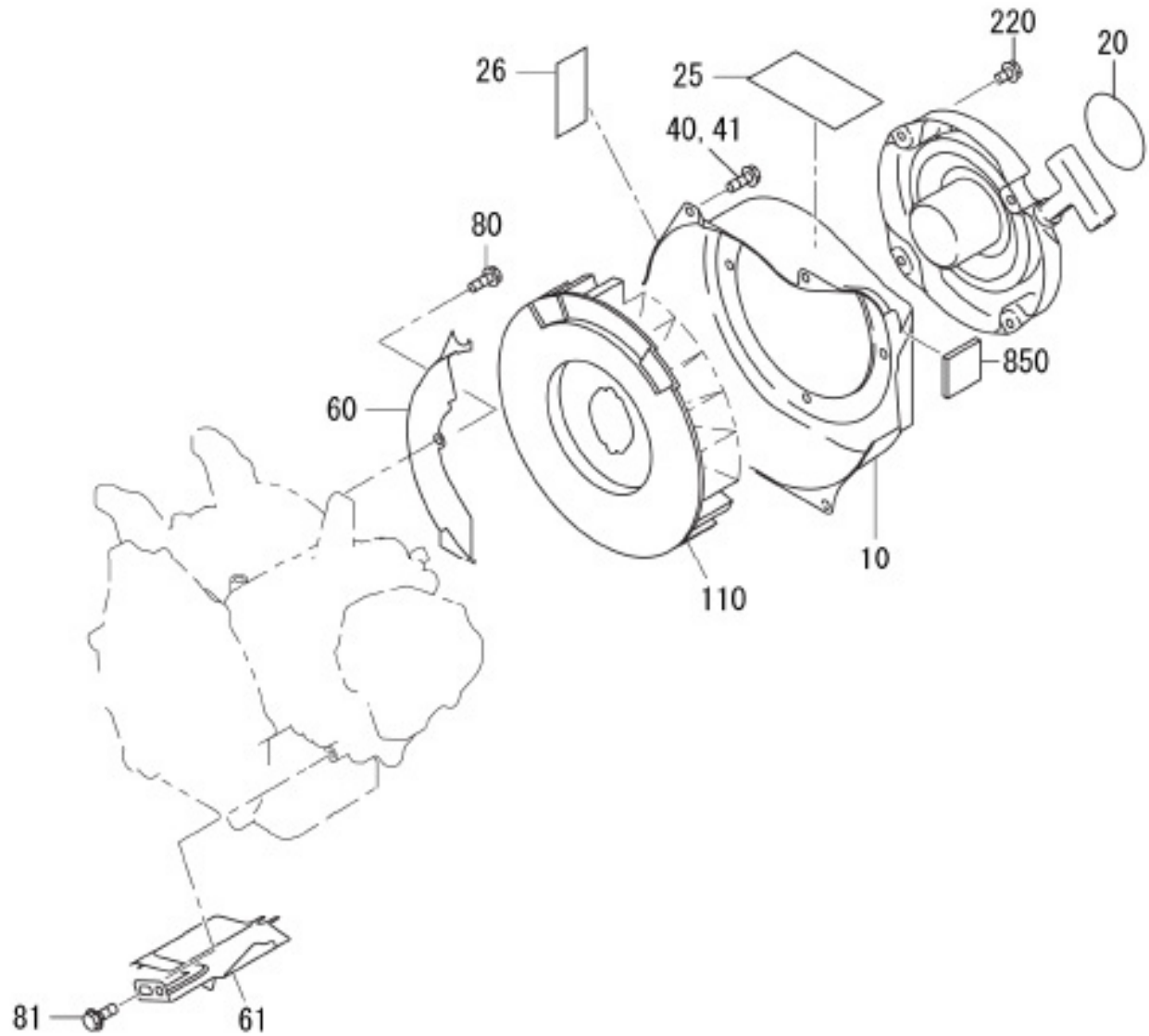

FIG. 520

RESIN

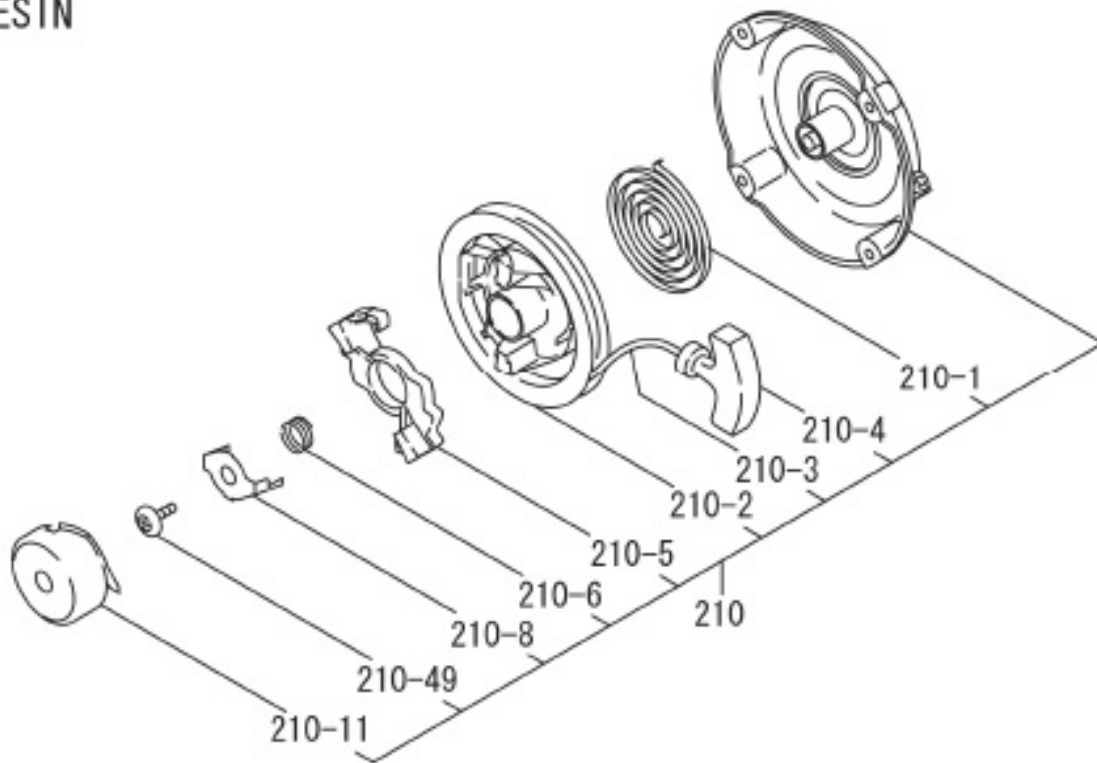

FIG. 600

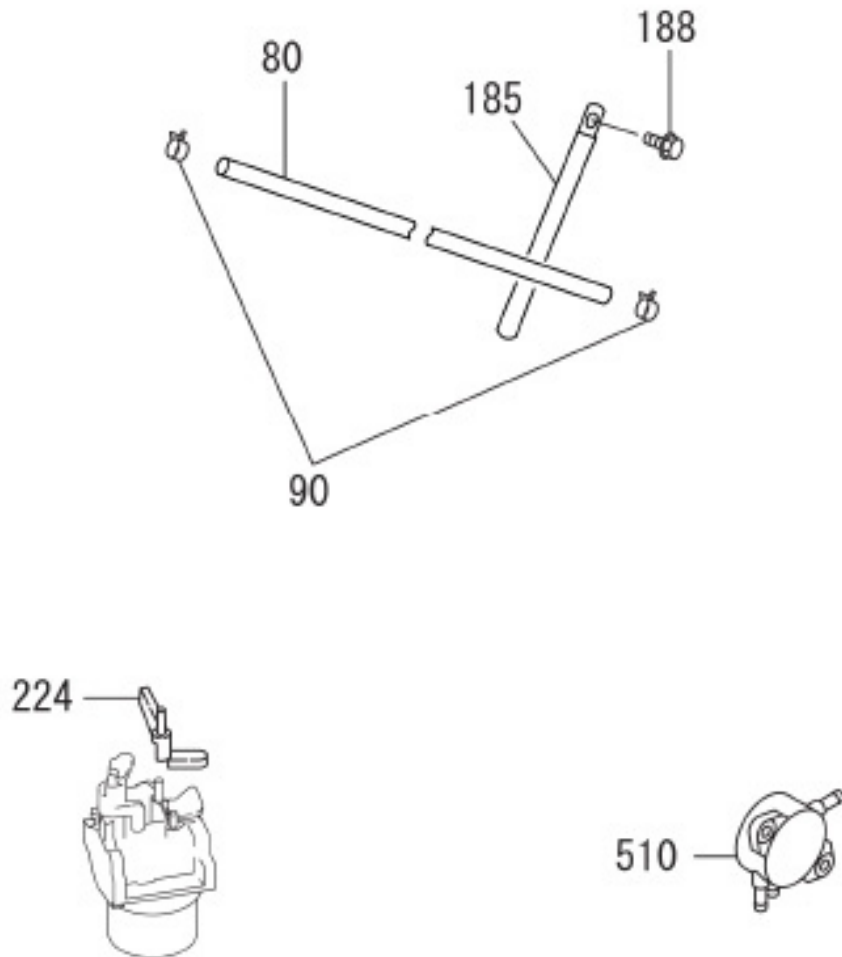

FIG. 642

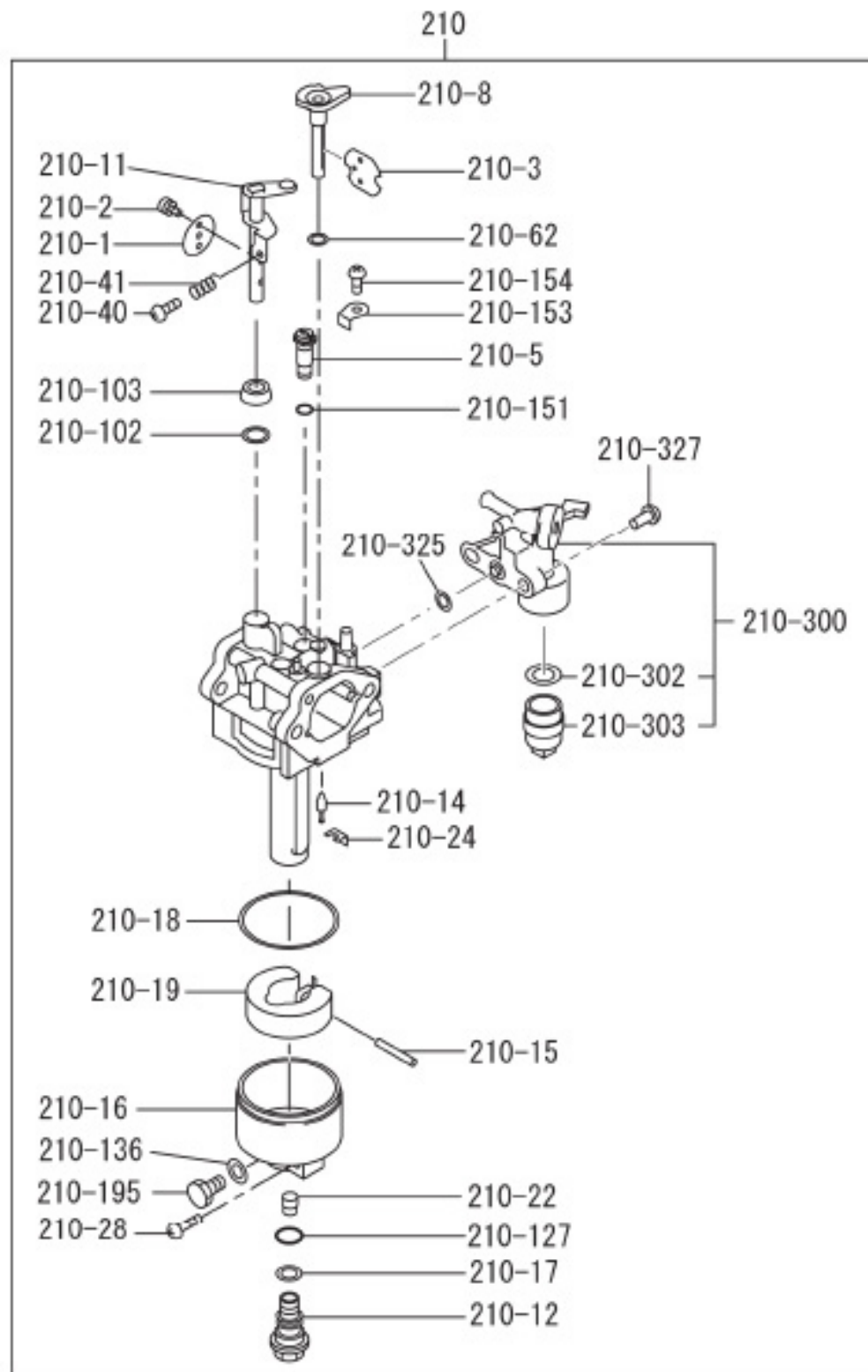

FIG. 700

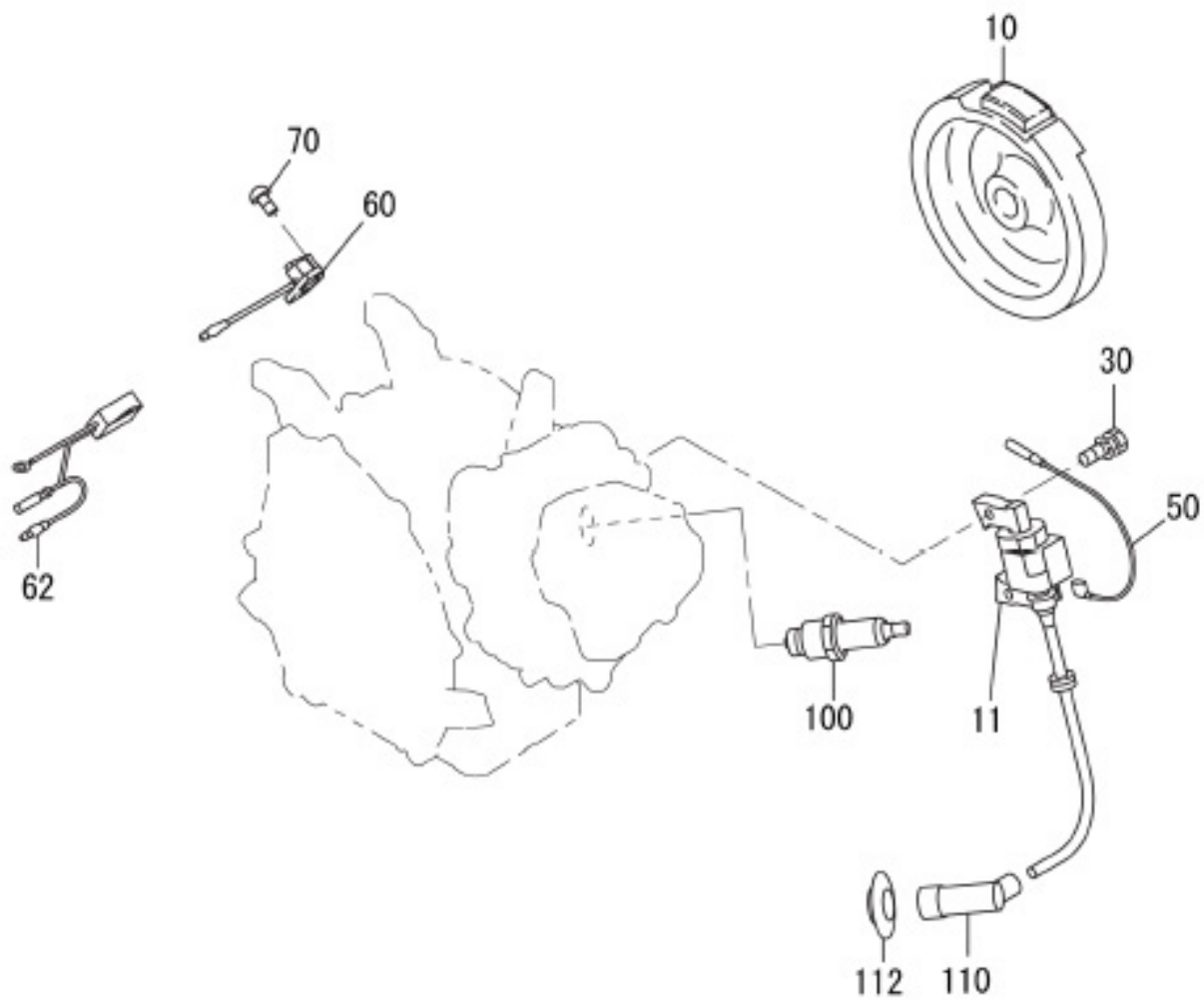

FIG. 900

